

VRC

Condensate collection tank



The condensate collection tank (VRC) has been designed to collect condensate returning from the steam system team and to mix it with the make-up softened or demineralised water.

Entirely made of AISI 316 L stainless steel.

Provided with:

- supporting legs
- upper manhole, connections and fittings

Product complete with level float control.

Should it be necessary to use a level control with probes, electric panel and solenoid valve, choose model

VRC-V

Standard equipment

- Water replenishment valve with float in STAINLESS steel
- Level indicator
- Drain valve

CODES AND MATCHING BOILERS

Model	Code	BNX	SIXEN	TReVAPOR	TReVAPOR P	GX
VRC 200	85520046	100 - 150	-	-	-	-
VRC 300	85520048	350	350	-	-	-
VRC 500	85520047	500	500	-	-	-
VRC 800	85520056	700 - 850	650 - 800	800	-	-
VRC 1000	85520045	1000	1000	1200	1200	-
VRC 1500	85520070	1400	1350 - 1700	1500	1500	-
VRC 2000	85520054	1700 - 2000	2000	2000	2000	1000 - 1200
VRC 2500	85520058	2650	2500	2500	2500	1500
VRC 3000	85520053	3000	3000	3000	3000	1750 - 2000
VRC 4000	85520074	-	3500 - 4000	3500 - 4000	3500 - 4000	2500
VRC 5000	85520075	-	5000	5000 - 6000	5000 - 6000 - 6500	3000

TECHNICAL DATA

Model	Nominal pressure	TS max. operating temperature	Total volume H2O	Empty weight
	bar	°C	lt	kg
VRC 200	0	90	200	32
VRC 300	0	90	300	41
VRC 500	0	90	500	56
VRC 800	0	90	800	71
VRC 1000	0	90	1000	78
VRC 1500	0	90	1500	118
VRC 2000	0	90	2000	150
VRC 2500	0	90	2500	164
VRC 3000	0	90	3000	213
VRC 4000	0	90	4000	278
VRC 5000	0	90	5000	358

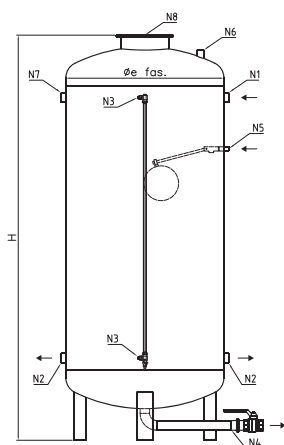

Key:

- N1 Condensate return inlet from steam using system
- N2 Boiler supply pump connection fittings
- N3 Level indicator fittings
- N4 Drain connection
- N5 Vessel supply with a float valve connected to water treatment system
- N6 Atmospheric vent releasing the re-evaporation steam into the environment
- N7 Overflow drain
- N8 Hatch

DIMENSIONS

Model	H	OD	N1	N2	N3	N4	N5	N6	N7	N8
	mm	mm	DN/in	DN/in	DN/in	DN/in	DN/in	DN/in	DN/in	DN/in
VRC 200	1420	450	1"1/4	1"1/4	1/2"	1"	1/2"	1"	1"1/4	240
VRC 300	1460	550	1"1/4	1"1/4	1/2"	1"	1/2"	1"	1"1/4	320
VRC 500	1900	600	1"1/4	1"1/4	1/2"	1"	1/2"	1"	1"1/4	320
VRC 800	1870	790	1"1/4	1"1/4	1/2"	1"1/4	1/2"	1"	1"1/4	320
VRC 1000	2140	800	1"1/4	1"1/4	1/2"	1"1/4	1/2"	1"	1"1/4	320
VRC 1500	2140	1000	2"	2"	1/2"	1"1/4	1/2"	1"	2"	400
VRC 2000	2230	1200	2"	2"	1/2"	1"1/4	3/4"	1"	2"	400
VRC 2500	2480	1200	2"	2"	1/2"	1"1/4	3/4"	1"	2"	400
VRC 3000	2750	1250	2"	2"	1/2"	1"1/4	3/4"	1"	2"	400
VRC 4000	2830	1400	2"	2"	1/2"	1"1/4	1"	1"	2"	400
VRC 5000	2860	1600	2"	2"	1/2"	1"1/4	1"	1"	2"	400

VRC-V

Condensate collection tank



The condensate collection tank (VRC-V) has been designed to collect condensate returning from the steam system team and to mix it with the make-up softened or demineralised water.

Entirely made of AISI 316 L stainless steel.

Provided with:

- supporting legs
- upper manhole, connections and fittings

Standard equipment

Make-up feed water unit including:

- Water solenoid valve complete with wiring to the control panel
- Tank internal conveyor tube

Automatic conductivity probe level regulator including:

- Solenoid valve opening probe
- Solenoid valve closing probe
- Probe for alarm and low level signalling
- Probe for alarm and high level signalling
- Glass level indicator

Boiler control panel IP55 1/N ~ 230V 50 Hz

CODES AND MATCHING BOILERS

Model	Code	BNX	SIXEN	TReVAPOR	TReVAPOR P	GX
VRC-V 200	85522005	100 - 150	-	-	-	-
VRC-V 300	85522010	350	350	-	-	-
VRC-V 500	85522015	500	500	-	-	-
VRC-V 800	85522020	700 - 850	650 - 800	800	-	-
VRC-V 1000	85522025	1000	1000	1200	1200	-
VRC-V 1500	85522030	1400	1350 - 1700	1500	1500	-
VRC-V 2000	85522035	1700 - 2000	2000	2000	2000	1000 - 1200
VRC-V 2500	85522040	2650	2500	2500	2500	1500
VRC-V 3000	85522045	3000	3000	3000	3000	1750 - 2000
VRC-V 4000	85522050	-	3500 - 4000	3500 - 4000	3500 - 4000	2500
VRC-V 5000	85522055	-	5000 - 6000	5000 - 6000	5000 - 6000 - 6500	3000

TECHNICAL DATA

Model	Nominal pressure	TS max. operating temperature	Total volume H2O	Empty weight
	bar	°C	l	kg
VRC-V 200	0	90	200	60
VRC-V 300	0	90	300	75
VRC-V 500	0	90	500	100
VRC-V 800	0	90	800	110
VRC-V 1000	0	90	1000	135
VRC-V 1500	0	90	1500	160
VRC-V 2000	0	90	2000	200
VRC-V 2500	0	90	2500	220
VRC-V 3000	0	90	3000	270
VRC-V 4000	0	90	4000	310
VRC-V 5000	0	90	5000	390

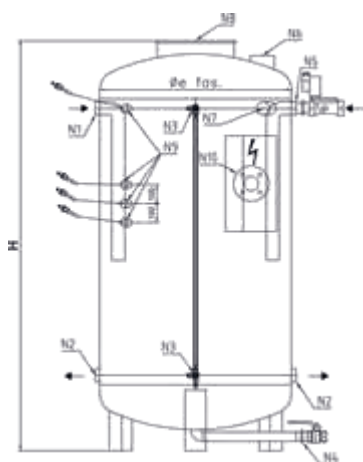

Key:

- N1 Condensate return inlet from steam using system
- N2 Boiler supply pump connection fittings
- N3 Level indicator fittings
- N4 Drain connection
- N5 Vessel supply with make-up valve connected to water treatment system
- N6 Atmospheric vent that directly leads re-evaporation steam into the atmosphere: make sure that tank is always at atmospheric pressure.
- N7 Overflow drain
- N8 Hatch
- N9 Level probe connections
- N10 Control panel support

DIMENSIONS

Model	H	OD	N1	N2	N3	N4	N5	N6	N7	N8	N9	N10
	mm	mm	DN/in	DN/in	DN/in	DN/in	DN/in	DN/in	DN/in	DN/in	DN/in	DN/in
VRC-V 200	1420	450	1"1/4	1"1/4	1/2"	1"	1"1/4	4"	1"1/4	240	1"	65
VRC-V 300	1460	550	1"1/4	1"1/4	1/2"	1"	1"1/4	4"	1"1/4	320	1"	65
VRC-V 500	1900	600	1"1/4	1"1/4	1/2"	1"	1"1/4	4"	1"1/4	320	1"	65
VRC-V 800	1870	790	1"1/4	1"1/4	1/2"	1"1/4	1"1/4	4"	1"1/4	320	1"	65
VRC-V 1000	2140	800	1"1/4	1"1/4	1/2"	1"1/4	1"1/4	4"	1"1/4	320	1"	65
VRC-V 1500	2140	1000	2"	2"	1/2"	1"1/4	2"	4"	2"	400	1"	65
VRC-V 2000	2230	1200	2"	2"	1/2"	1"1/4	2"	4"	2"	400	1"	65
VRC-V 2500	2480	1200	2"	2"	1/2"	1"1/4	2"	4"	2"	400	1"	65
VRC-V 3000	2750	1250	2"	2"	1/2"	1"1/4	2"	4"	2"	400	1"	65
VRC-V 4000	2830	1400	2"	2"	1/2"	1"1/4	2"	4"	2"	400	1"	65
VRC-V 5000	2860	1600	2"	2"	1/2"	1"1/4	2"	4"	2"	400	1"	65