

BDV

Blowdown vessel



The BDV blowdown vessel has been designed to receive sludge that usually settle at the bottom of the steam boilers which is discharged during a bottom blowdown operation; this sludge is cooled and allowed to settle at the bottom of the tank before being discharged to the sewer thus limiting any risks for the operator and damage to the environment.

The blowdown vessel complies with the PED Directive 2014/68/EU

Provided with:

- steel sheet supporting legs
- connections and fittings

Standard equipment

- Drain valve
- Cooling system by means of solenoid valve and thermostat

BOILERS THAT CAN BE MATCHED

Model	FX N	FX DUAL N	BNX	SIXEN N	TReVAPOR	TReVAPOR P	GX
BDV 50	50 - 100 - 150	100 - 200 - 300	100 - 1700	350 - 1700	800 - 1500	1200 - 1500	-
BDV 100	-	-	2000 - 3000	2000 - 5000	2000 - 5000	2000 - 5000	1000 - 3000
BDV 200	-	-	-	-	6000	6000 - 6500	3500 - 12000

PRODUCT CODES

Model	Code	Nominal pressure	Total volume H2O	Total weight
		bar	lt	kg
BDV 50	85520064	12	500	250
BDV 100	85520085	12	1000	350
BDV 200	85520202	12	2000	650

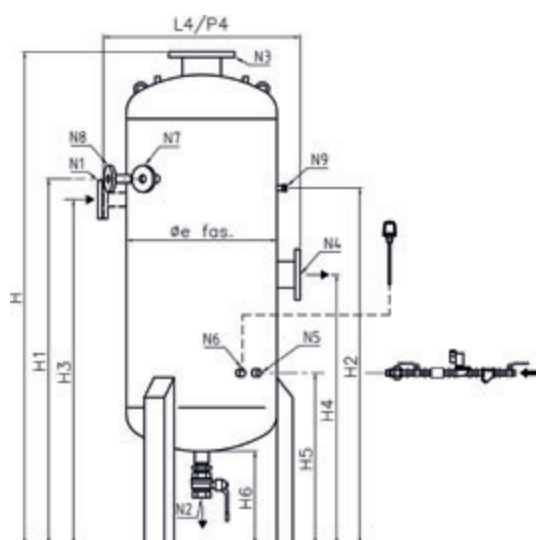

- Key:
- N1 Blowdown inlet
 - N2 Drainage
 - N3 Atmospheric vent
 - N4 Overflow
 - N5 Cooling system
 - N6 Thermostat
 - N7 Boiler level indicator blowdown connections
 - N8 Boiler salinity blowdown connection
 - N9 Manometer

DIMENSIONS

BDV	H	H1	H2	H3	H4	H5	H6	L4	P4	OD	N1	N2	N3	N4	N5	N6	N7	N8	N9
	mm	mm	mm	mm	mm	mm	mm	mm	mm	mm	DN/in	DN/in	DN/in	DN/in	DN/in	DN/in	DN/in	DN/in	DN/in
50	2174	1580	1540	1490	1165	740	400	934	934	650	50	2"	150	100	3/4"	3/4"	25	25	1/2"
100	2774	2130	2090	2040	1215	790	400	1082	1082	800	50	2"	150	100	3/4"	3/4"	25	25	1/2"
200	2934	2210	2170	2120	1295	870	400	1382	1382	1100	50	2"	150	100	3/4"	1"	25	25	1/2"